

Quench Distortion of Keyed Shaft

Background and Problem:

Quench distortion during heat treatment is a commonly encountered problem in metal processing industries. It is considered extremely complex and is attributed to material and thermal properties of the work-piece, and quenchant properties. Phase transformations in steels further complicate the phenomenon.

It was observed that during quenching, steel shafts tended to distort more severely if they contained keyways. Non-uniform cooling due to the non-axisymmetric geometry may have been responsible for inducing the additional distortion.

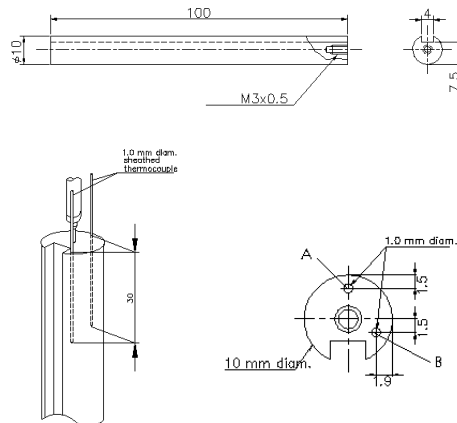

Fig. 1. Specimen dimensions and location of instrumented specimen thermocouple holes.

Shafts were austenitized at 850°C for 20 minutes before quenching into non-agitated water, maintained at 30°C. Heat transfer coefficients for simulation were obtained from the Lumped-Heat-Capacity method, which modified the cooling curve measurements from the instrumented quench experiments.

Quenchant boiling characteristics and specimen distortion were recorded by video, and are displayed in Fig. 2.

The progressive collapse of the vapor blanket started from the keyway side (the left side in Fig. 2). The ultimate Hardness values were measured in the range 55 ~ 60 HRC suggesting that the steel was primarily martensite.

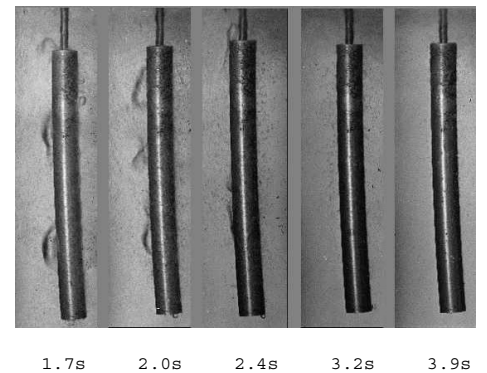
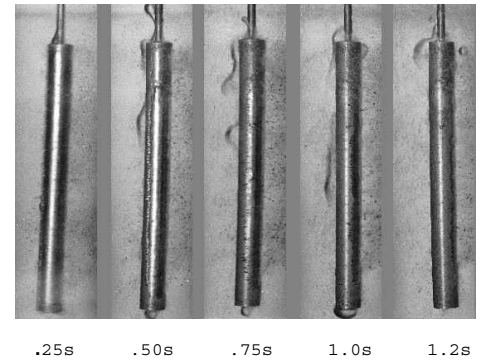

Fig. 2. Boiling behavior and distortion during quenching in still city water at 30°C. Keyway is on left side of specimen.

Analysis:

DEFORM™-HT was used in non-isothermal mode, to simulate the shaft quenching processes. One half of the shaft geometry was analyzed, symmetry being applied. 34,000 tetrahedral elements made up the FEM mesh and an elasto-plastic object type was used. Material and thermal properties were obtained for the austenite, martensite and pearlite phases of the AISI-1045 steel. Inter-phase data and transformation kinetics described the phase transformations taking place. The

(continued on other side)

(continued from the other side)

Johnson-Mehl relationship, combined with a TTT diagram, was used for the austenite-pearlite phase change, whereas a martensitic expression described the austenite-martensite transformation progression.

Results

The simulated quench distortion history is shown in Fig. 3. Excellent correlation between predicted and actual distortion is evident, as shown by comparing Fig. 2 and Fig. 3. From both experiment and simulation, the shaft bent toward the keyway side initially, then after 1.1 seconds, bent in the opposite direction. It is proposed that the initial deflection arose as a result of the early thermal shrinkage on the keyway side. The subsequent distortion (after approximately 1.1 seconds) was initially due to the early volume expansion of martensite around the keyway. It is believed that the final distortion resulted from the tensile plastic stress, in the keyway side of the shaft, which accumulated during the initial second of cooling.

Martensite was predicted as the dominant phase after quenching, which agrees directly with hardness measurements on the actual specimens: measurements in the range 55 ~ 60 HRC suggest a primarily martensitic microstructure.

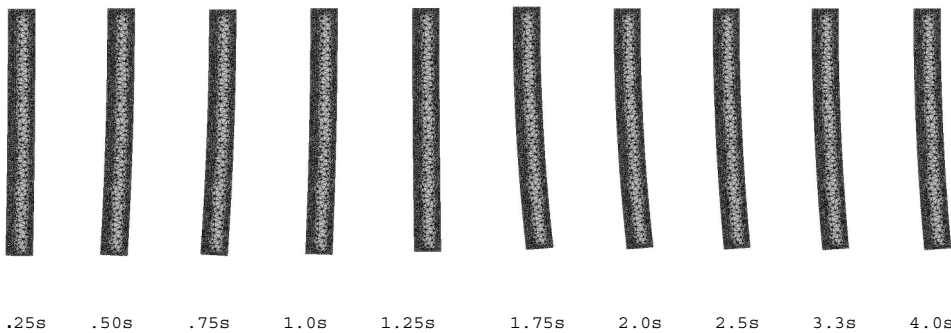

Fig. 3. Simulated quench distortion history during non-agitated water quenching

Opportunities

As this analysis shows, quenching is a very complex phenomenon. In such a process, there are quite a few variables, including heat transfer, plastic deformation, and phase transformation, which have interacting effects. A change in one will inevitably affect the others. DEFORM™-HT permits the designer to analyze all these effects at once, allowing them to visualize stress and deformation during the quenching process.

In the case of the keyed shaft, the designer may never have become aware of the shaft's initial bend direction during quenching. Without this information, trying to improve or trouble shoot the quenching process would be very difficult and time-consuming. Process simulation allows the designer to "see inside" a complex phenomenon such as this, making it easier to understand. Fully understanding the process is often required before improvements to the process can be made.

Designing or improving a quenching process the traditional way may take a number of days or weeks, and may result in large numbers of scrapped components. Using simulation, the lead time can be drastically reduced and scrapped components can be avoided. In addition, DEFORM™ allows more "what ifs" to be carried out, allowing the design of a component to be the optimum one, and not just adequate.

**Scientific
Forming
Technologies
Corporation**



5038 Reed Road
Columbus, Ohio
43220-2514
Tel: (614)451-8330
Fax: (614)451-8325

www.deform.com

[email: sales@deform.com](mailto:sales@deform.com)